

Available from:
FILQUIP Pty Limited

5/126 Compton Rd, Underwood,
Qld 4119 Australia
Ph: +61 7 3208 3499 Fx: +61 7 3208 3449
Email: sales@filquip.com.au
www.filquip.com.au

Laboratory Mixer

MLH 06
MLH 12
MLH 30

ECONOMIC LAB
EQUIPMENT



Laboratory Mixer

MLH 6
MLH 12
MLH 30

THE MLH LABORATORY MIXER IS THE IDEAL SOLUTION FOR ANY PRODUCT OR PROCESS DEVELOPMENT, AS WELL AS FOR SMALL SCALE PRODUCTION

The MLH Laboratory Batch Mixer consists of stand-alone drive unit with incorporated frequency inverter, an easily replaceable horizontal mixing shaft supported at the drive end only, and an easily replaceable, revolving mixing vessel complete with inlet/outlet.

MLH Laboratory Batch Mixers operate on the principle of a mechanically generated fluid bed. This ensures product and process development as required by the industry today. The quick change of drum size combined with a rich basic equipment package ensures the use for a variety of applications.

In some cases, to obtain the desired mixing effect, separately driven high-speed choppers can be installed.

MLH is a Laboratory Batch Mixer suitable for applications in the pharmaceutical, food, chemical, biochemical, and powder metallurgy industry.

Features

- Total volume: 6 - 12 - 30 litres
- Working volume: min. 1.2, max. 24 litres
- Adjustably geared motor with variobloc
- Mixer drive: 2.2 kW
- Frequency: 50 – 60 Hz
- Chopper drive: 0.12 kW
- Chopper speed: 1,450 rpm
- Weight: 260 kg

- Ready for use
- Mixer and casing in stainless steel
- Mixer completely assembled and tested
- Ploughshare tools
- Table top design or free standing mounted on rollers
- Electronic control of mixer shaft rotation speed
- Control unit integrated into mixer casing
- Feeding hopper

Overall Dimensions

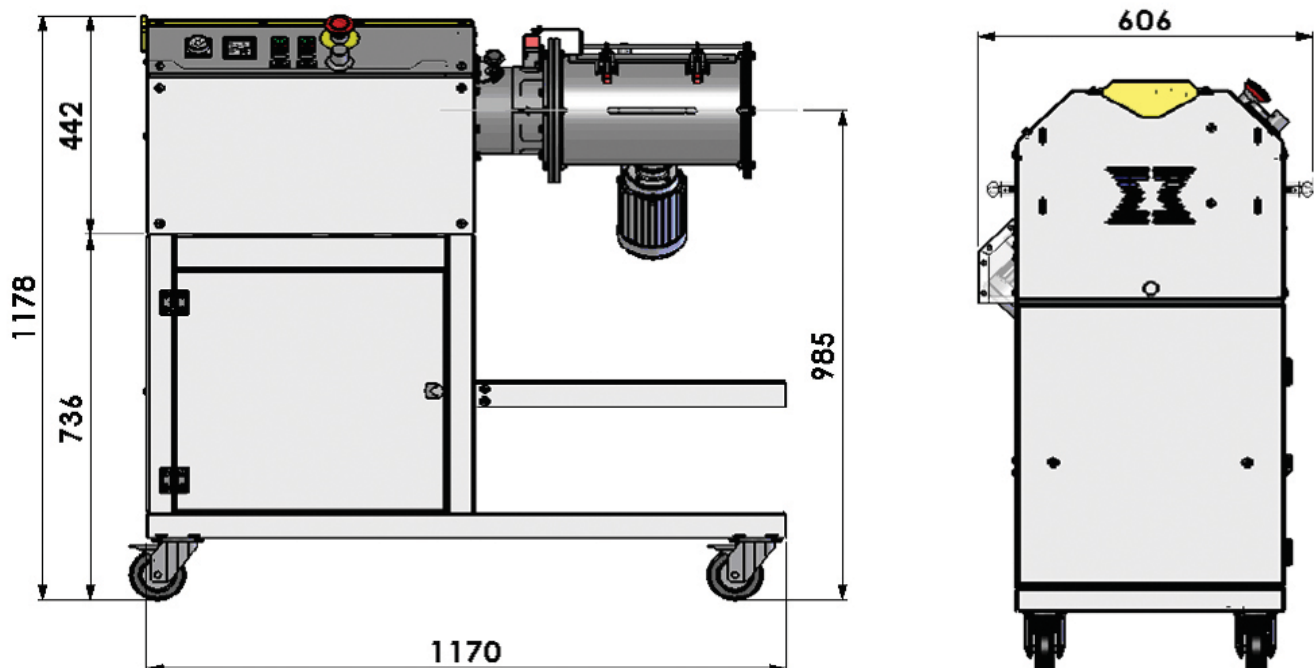

Benefits

- ✓ Short mixing time;
- ✓ Ideal for your product and process development;
- ✓ Attractive price;
- ✓ Table top or free standing;
- ✓ Variety of options;
- ✓ Easy to use and maintain;
- ✓ Stainless steel construction;
- ✓ Easy cleaning system;
- ✓ Quick and easy shaft interchangeability;
- ✓ Ergonomic handling.

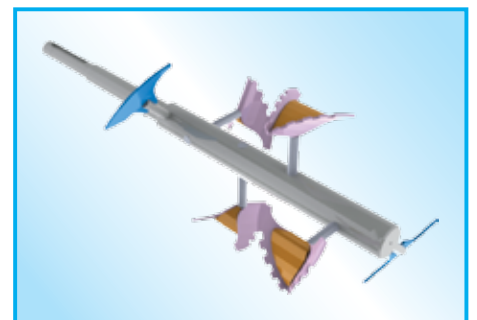
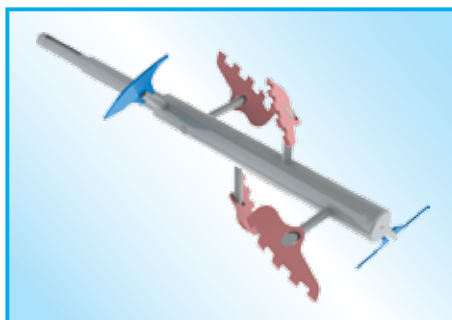
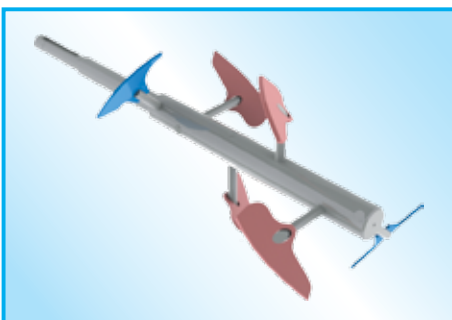
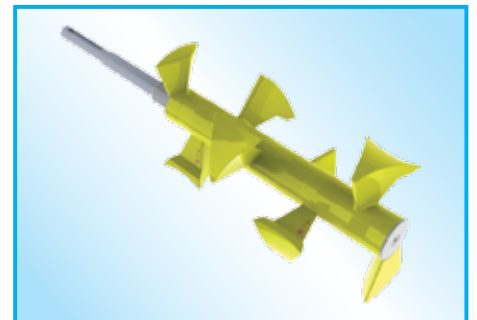
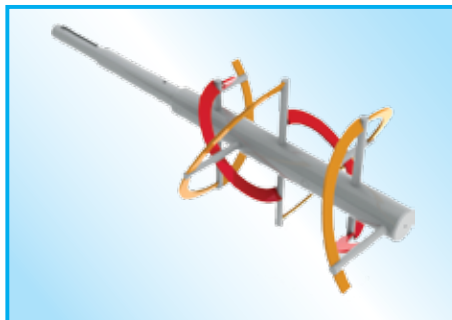
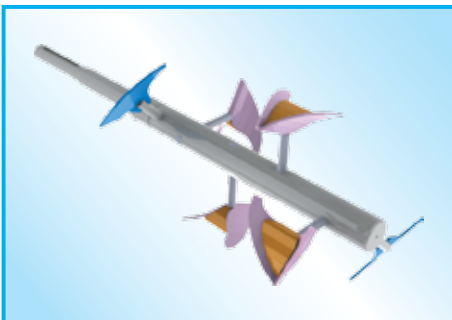
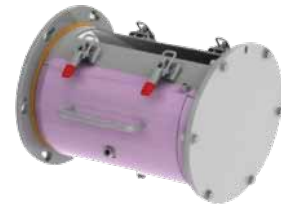

Applications



DETERGENTS



PHARMACEUTICALS



COSMETICS



CHEMICALS



FOODS



ANIMAL FEED



BUILDING MATERIALS



MINERALS

Available from:
FILQUIP Pty Limited

5/126 Compton Rd
 Underwood Qld 4119
 Australia
 Phone: +61 7 3208 3499
 Fax: +61 7 3208 3449
 Email: sales@filquip.com.au
 www.filquip.com.au



063001462 September 2012 Rights reserved to modify technical specifications.



www.wamgroup.com