

Batch-Type Ploughshare Mixers with Bomb Bay Discharge

Pflugscharmischer für Chargenbetrieb mit Integralentleerung

Mélangeurs Discontinus à Socs avec Déchargement Total

Mescolatori Discontinui a Vomere Scarico Totale

WBHT - WBHP



Available from:

FILQUIP Pty Limited

5/126 Compton Rd, Underwood,

Qld 4119 Australia

Ph: +61 7 3208 3499 Fx: +61 7 3208 3449

Email: sales@filquip.com.au

www.filquip.com.au



The horizontal single shaft Ploughshare Mixer is based on the principle of mechanical fluidisation of the product.

The particular shape, position and rotation speed of the mixing tools, creates a centrifugal vortex motion which allows the products to be projected in a three-dimensional way and to merge with each other.

This ensures that components with a different particle size and bulk density are perfectly blended and mixed with high precision within the shortest possible time.

Bomb-Bay Discharge Batch Mixers, type WBHT with 60° opening section and WBHP with 15° opening section satisfy any customer's requirement in terms of high quality mixing in batch-type processes which are oriented towards optimized efficiency. An outlet opening across the entire length of the mixing vessel ensures virtually residue-free discharge of the product in the shortest possible time.

Die horizontalen Einwellen-Wurfschaufelmischer arbeiten nach dem Prinzip der mechanischen Fluidisierung von Feststoffen mittels Mischwerkzeugen.

Die besondere Bauform, die Anordnung und die Rotationsgeschwindigkeit der Mischwerkzeuge bewirken eine dreidimensionale Turbulenz, bei der das Mischgut auch dann optimal homogenisiert wird, wenn die einzelnen Komponenten unterschiedliche Körnungen und Schüttgewichte aufweisen.

Die Integralentleerung der Chargenmischer WBHT mit 60° und WBHP mit 15° Auslauföffnung entspricht den Wünschen der Anwender nach höherer Leistung und erhöhter Mischqualität in Chargenprozessen, in denen die Optimierung der Produktivität oberstes Ziel ist.

Der über die gesamte Länge der Mischkammer reichende Auslauf gewährleistet eine nahezu augenblickliche, rückstands-freie Entleerung des Mixers.

Ces mélangeurs horizontaux à arbre simple se basent sur le principe de la fluidification mécanique des produits.

Leur construction sous une forme particulière, la disposition et la vitesse de rotation des outils de mélange, créent un mouvement tourbillonnaire centrifuge qui permet la projection tridimensionnelle et leur inter-pénétration. La parfaite homogénéisation et la haute précision de mélange sont ainsi garantis, même quand la granulométrie et le poids spécifique des composants sont différents.

La vidange totale des mélangeurs discontinus WBHT avec ouverture à 60° et WBHP avec ouverture à 15° satisfait les exigences de capacités élevées de haute qualité de mélange dans des procédés discontinus orientés à l'optimisation de la productivité.

La bouche de déchargement le long de toute la longueur de la cuve de mélange garantit une vidange du produit avec résiduel quasiment nul et en temps très court.

I mescolatori ad albero orizzontale a vomere si basano sul principio della fluidificazione meccanica dei prodotti.

La particolare forma di costruzione, la disposizione e la velocità di rotazione degli utensili di mescolazione, creano un moto vorticoso centrifugo che permette la proiezione tridimensionale dei prodotti e la loro compenetrazione.

Ciò assicura, in tempi brevissimi, una perfetta omogeneizzazione e un'alta precisione di mescolazione anche di componenti con granulometria e peso specifico diverso. Lo scarico totale dei mescolatori discontinui WBHT con scarico a 60° e WBHP con scarico a 15° soddisfa le esigenze di elevata capacità ed alta qualità di miscela in processi discontinui orientati all'ottimizzazione della produttività.

La bocca di scarico lungo tutta la lunghezza della camera di miscelazione garantisce uno svuotamento del prodotto con residui quasi nulli ed in tempi brevissimi.



Application - Anwendungen - Applications - Applicazioni



Foods

Nahrungsmittel

Alimentaires

Alimentari



Ceramic Dust

Keramikstäube

Poussières céramiques

Polvere di ceramica



Pharmaceutical Products

Pharmazeutische Produkte

Produits pharmaceutiques

Prodotti farmaceutici



Building Materials

Baustoffe

Matériaux de bâtiment

Materiali edili

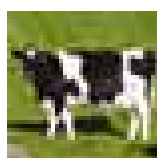

Animal Feed

Futtermittel

Aliments pour animaux

Zootecnica



Chemicals

Chemieprodukte

Chimie

Chimica

WBHT

60° Bomb Bay Door

60° Integralentleerung

60° vidange totale

60° scarico totale

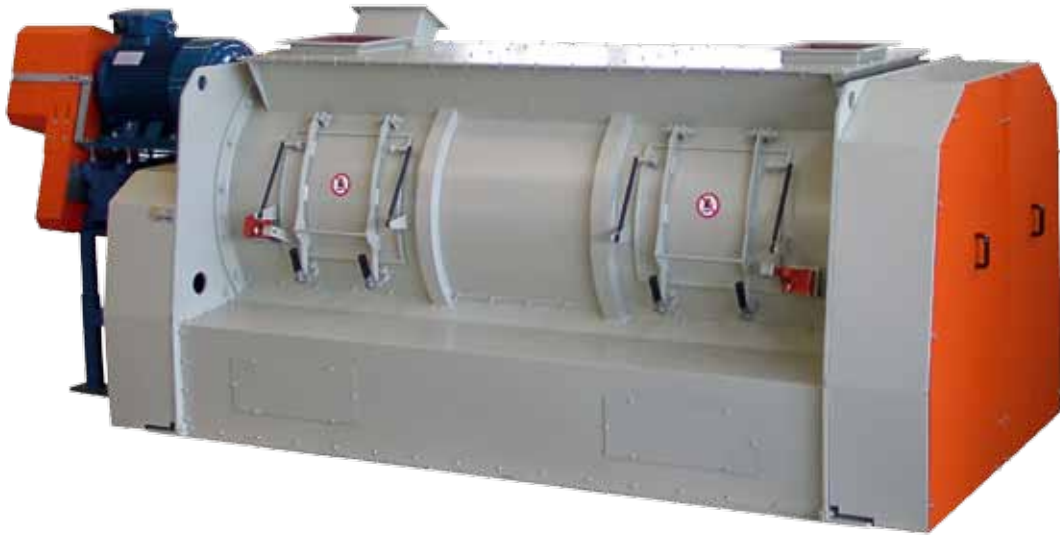

WBHP

15° Bomb Bay Door

15° Integralentleerung

15° vidange totale

15° scarico totale



REGISTERED LABORATORY APPROVED BY THE ITALIAN MINISTRY OF SCIENCE AS PUBLISHED IN THE "GAZZETTA UFFICIALE" No. 120 DATED 24TH MAY, 1996.

EINGETRAGENES UND VOM ITALIENISCHEN WISSENSCHAFTSMINISTERIUM ANERKANNTES LABORATORIUM GEMÄSS VERÖFFENTLICHUNG IN DER „GAZZETTA UFFICIALE“ Nr. 120 VOM 24. MAI 1996.

LABORATOIRE INSCRIT ET RECONNU PAR LE MINISTERE DE SCIENZE ITALIEN COMME PUBLI DANS « LA GAZZETTA UFFICIALE » N. 120 DU 24 MAI 1996.

LABORATORIO ISCRITTO E RICONOSCIUTO DAL MINISTERO DELLA RICERCA SCIENTIFICA COME PUBBLICATO SULLA GAZZETTA UFFICIALE N° 120 DEL 24 MAGGIO 1996.



- Mixing of Solids
- Mischen von Feststoffen
- Malaxage de produits solides
- Mescolazione di solidi



- Treatment of Solids with Liquids
- Behandlung von Feststoffen mit Flüssigkeiten
- Traitement de produits secs avec de liquidess
- Trattamento solidi con liquidi



- Mixing of Highly Viscous Materials
- Mischen von Medien mit hoher Viskosität
- Traitement des matières à haute viscosité
- Trattamento materiali ad alta viscosità

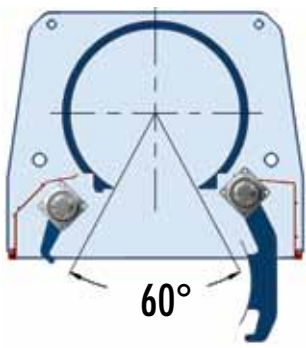

WBHT

60° Bomb Bay Door

60° Integralentleerung

60° vidange totale

60° scarico totale

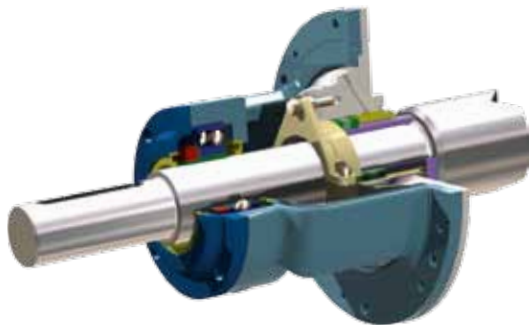

End Bearing Assemblies in Various Shaft Seal Configurations and with the Option of Air or Nitrogen Purging

Endlagereinheiten mit unterschiedlichen Wellenabdichtungskonfigurationen sowie der Option der Sperrspülung mittels Luft oder Stickstoff

Paliers d'extrémité équipés de diverses configurations et avec l'option de pressurisation à l'air ou à l'azote

Supporti di estremità completi di tenuta (disponibili in diverse configurazioni) con l'opzione di insufflaggio ad aria o ad azoto

Flush Discharge Valve

Totraumfreie Entleerklappe

Porte de vidange reconstituant la courbure de la cuve (pas de zone morte)

Portello di scarico con ripristino della superficie interna della camera di mescolazione

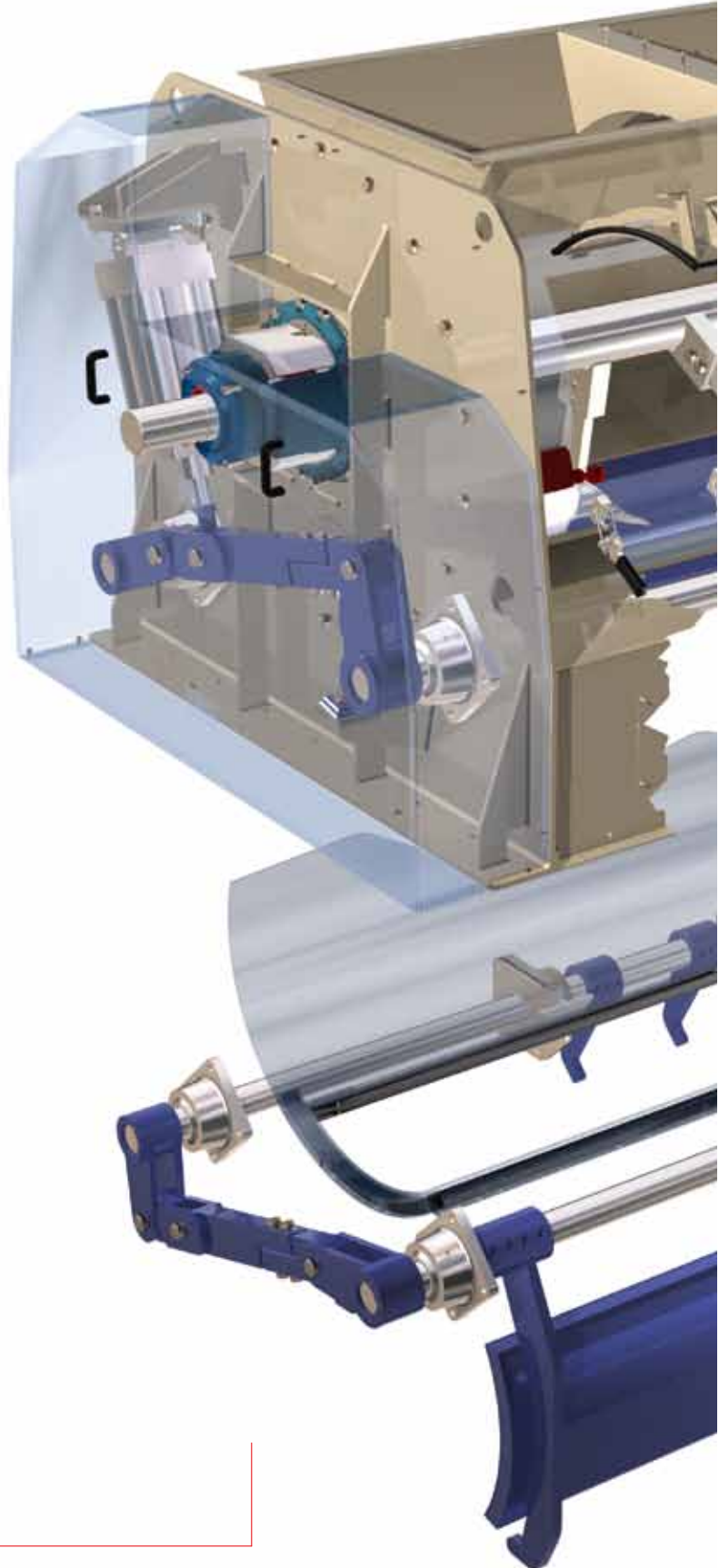

- Maximum Mixing Homogeneity
- Short Mixing Time (1 - 4 minutes)
- Excellent Reproducibility of Batches
- Minimum Wear / Low Maintenance
- Easy Access to Mixer
- Total Emptying / Minimum Residue
- Perfect Bomb Bay Door Sealing

- Optimale Mischhomogenität
- Verringerte Mischzeiten (1 - 4 min)
- Chargen-Scale-Up
- Geringer Verschleiß / wartungsarm
- Mischer leicht zugänglich
- Totalentleerung /minimale Materialrückstände
- Hochwirksame Entleerklappenabdichtung

- Homogénéité maximum du mélange
- Temps de mélange moins long (1 - 4 minutes)
- Lots reproductibles à l'échelle
- Usure minimum / moins entretien
- Accès facile au mélangeur
- Vidange totale / résiduel minimum
- Étanchéité parfaite sur la porte de déchargement

- Massima omogeneità di miscela
- Tempo di mescolazione breve (1 - 4 minuti)
- Riproducibilità eccellente dei batch
- Usura minima / manutenzione ridotta
- Facile accesso al mescolatore
- Totale svuotamento / minimo residuo
- Perfetta tenuta sul portello di scarico

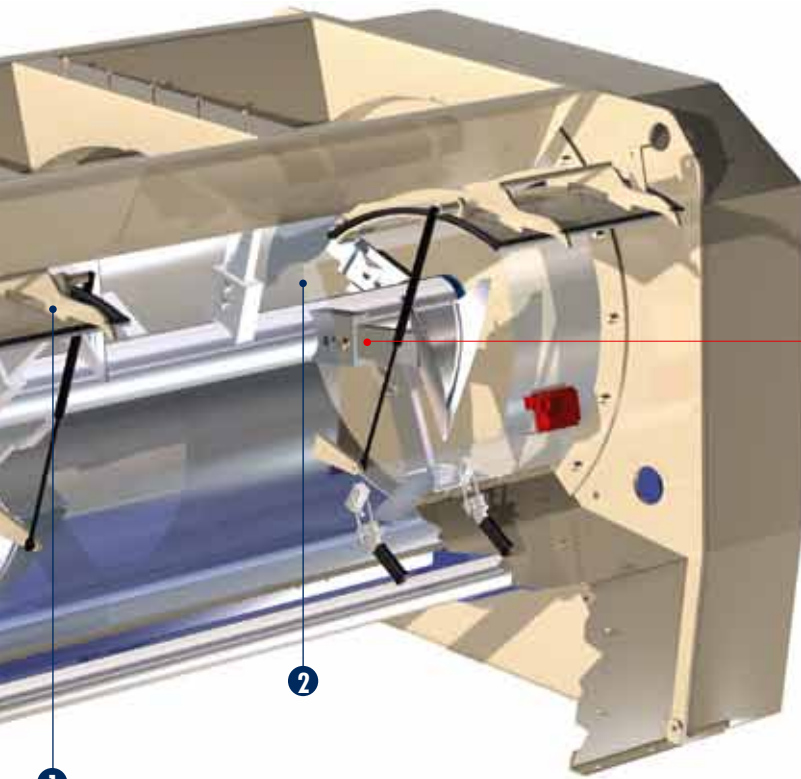

Easy Tool Adjustment and Replacement

Einfacher Austausch und Einstellung der Mischwerkzeuge

Réglage et remplacement aisé des outils

Facile regolazione e sostituzione degli utensili



1 Easy Cleaning and Access to All Internal Parts of the Mixer

Einfache Reinigung und Zugänglichkeit aller im Inneren der Mischkammer befindlichen Teile

Nettoyage facile et accessibilité élevée à toutes les parties internes du mélangeur

Facile pulizia ed elevata accessibilità a tutte le parti interne del mescolatore



2 Heavy-Duty Mixing Chamber Manufactured in Carbon Steel, Anti-Wear Steel, or 304 - 304L - 316 - 316L Stainless Steel

Dickwandige Mischkammer aus Stahl, verschleißresistentem Stahl, oder Edelstahl (1.4301 - 1.4306 - 1.4401 - 1.4404)

Cuve de mélange de forte épaisseur en acier au carbone, acier antiusure, ou en acier inox (304 - 304L - 316 - 316L)

Camera di mescolazione ad alto spessore in acciaio al carbonio, acciaio antiusura o in acciaio inox (AISI 304, 304L, 316, 316L)

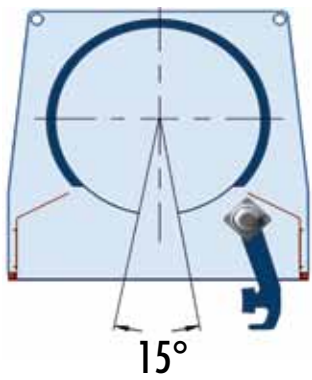

WBHP

15° Bomb Bay Door

15° Integralentleerung

15° vidange totale

15° scarico totale

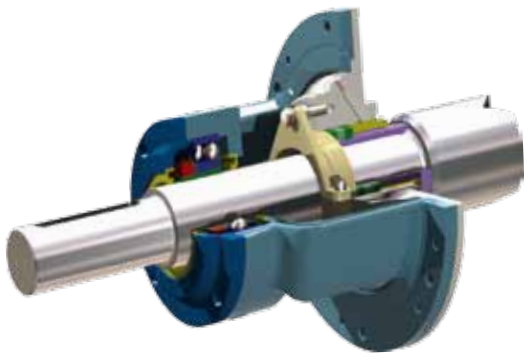

End Bearing Assemblies in Various Shaft Seal Configurations and with the Option of Air or Nitrogen Purging

Endlagereinheiten mit unterschiedlichen Wellenabdichtungskonfigurationen sowie der Option der Sperspülung mittels Luft oder Stickstoff

Paliers d'extrémité équipés de diverses configurations et avec l'option de pressurisation à l'air ou à l'azote

Supporti di estremità completi di tenuta (disponibili in diverse configurazioni) con l'opzione di insufflaggio ad aria o ad azoto

Flush Discharge Door

Totraumfreie Entleerklappe

Porte de vidange reconstituant la courbure de la cuve (pas de zone morte)

Portello di scarico con ripristino della superficie interna della camera di mescolazione

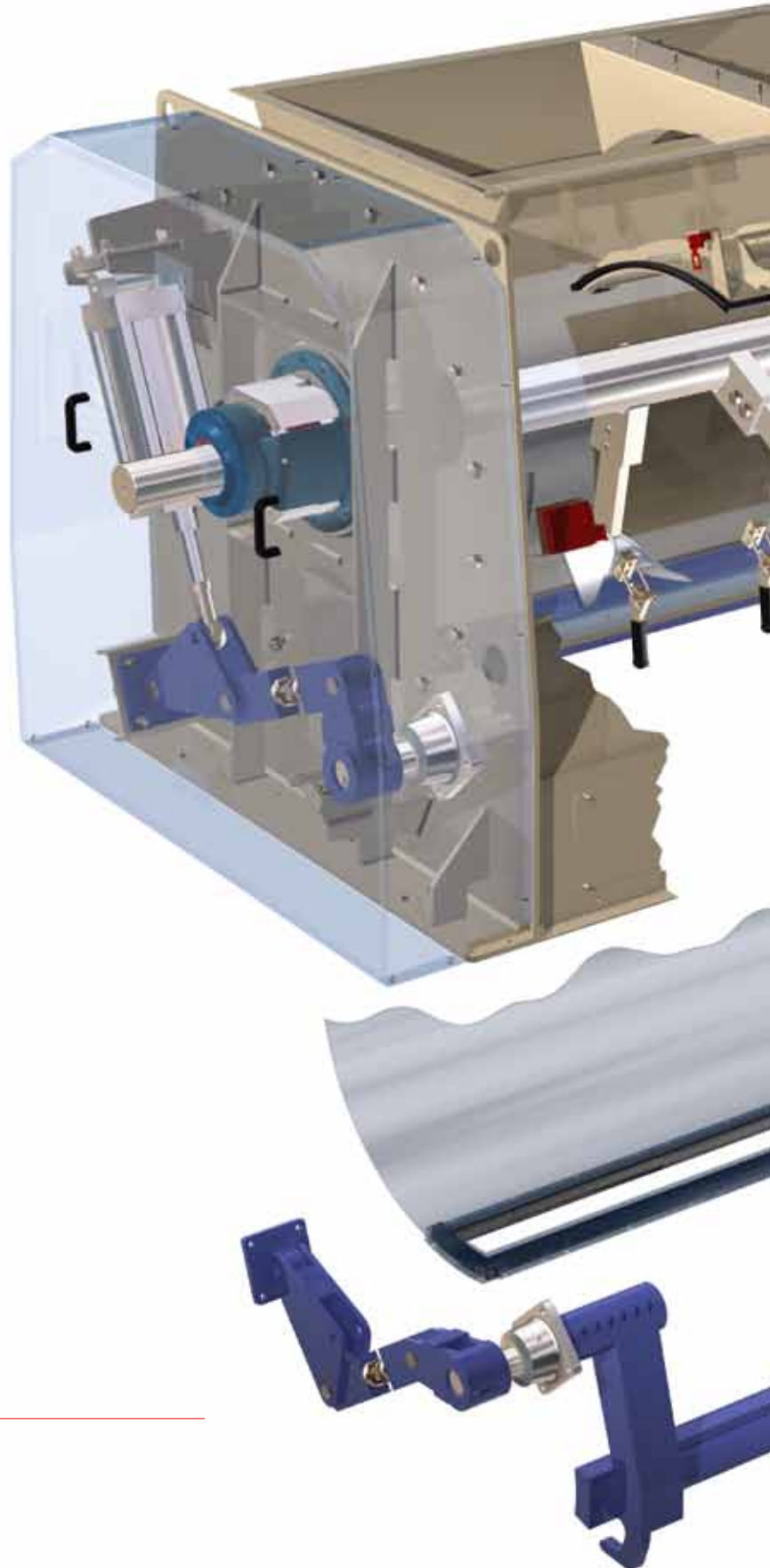

- Maximum Mixing Homogeneity
- Short Mixing Time (1 - 4 minutes)
- Excellent Reproducibility of Batches
- Minimum Wear / Low Maintenance
- Easy Access to Mixer
- Complete emptying, minimum residue
- Perfect bomb bay door sealing

- Optimale Mischhomogenität
- Verringerte Mischzeiten (1 - 4 min)
- Chargen-Scale-Up
- Geringer Verschleiß / wartungsarm
- Mischer leicht zugänglich
- Komplette Entleerung / minimale Restmengen
- Perfekte Klappenabdichtung

- Homogénéité maximum du mélange
- Temps de mélange moins long (1 - 4 minutes)
- Lots reproductibles à l'échelle
- Usure minimum / moins entretien
- Accès facile au mélangeur
- Vidange totale / résiduel minimum
- Étanchéité élevée de la garniture

- Massima omogeneità di miscela
- Tempo di mescolazione breve (1 - 4 minuti)
- Riproducibilità eccellente dei batch
- Usura minima / manutenzione ridotta
- Facile accesso al mescolatore
- Totale svuotamento / minimo residuo
- Elevata tenuta della guarnizione

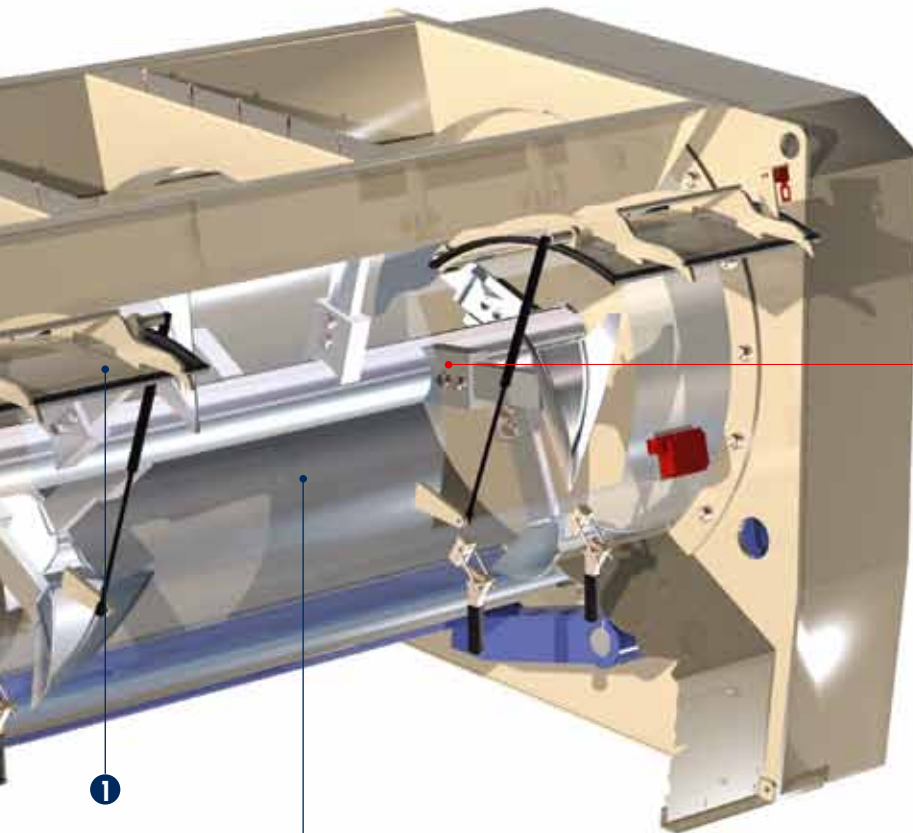

Easy Tool Adjustment and Replacement

Austausch und Einstellung der Mischwerkzeuge denkbar einfach

Réglage et remplacement aisés des outils

Facile regolazione e sostituzione degli utensili



1

2

1 Easy Cleaning and Access to All Internal Parts of the Mixer

Einfache Reinigung und Zugänglichkeit aller im Inneren der Mischkammer befindlichen Teile

Nettoyage facile et accessibilité élevée à toutes les parties internes du mélangeur

Facile pulizia ed elevata accessibilità a tutte le parti interne del mescolatore



2 Heavy-Duty Mixing Chamber Manufactured in Carbon Steel, Anti-Wear Steel, or 304 - 304L - 316 - 316L Stainless Steel

Dickwandige Mischkammer aus Stahl, verschleißresistentem Stahl, oder Edelstahl (1.4301 - 1.4306 - 1.4401 - 1.4404)

Cuve de mélange de forte épaisseur en acier au carbone, acier antiusure, ou en acier inox (304 - 304L - 316 - 316L)

Camera di mescolazione ad alto spessore in acciaio al carbonio, acciaio antiusura o in acciaio inox (AISI 304, 304L, 316, 316L)





Standard Mixing Tool
Standard-Mischwerkzeug
Soc standard
Vomere standard



Boxed Mixing Tool
Geschlossenes Mischwerkzeug
Soc en caisson
Vomere scatoiato

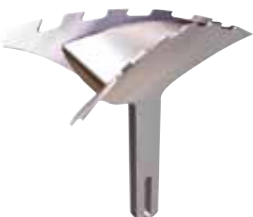

Toothed Edge Mixing Tool
Stollen-Mischwerkzeug
Soc denté
Vomere dentato



Blade-Type Mixing Tool
Schrägschaufel-Mischwerkzeug
Lame lisse
Lama liscia



Toothed Blade Mixing Tool
Stollen-Schrägschaufel-Mischwerkzeug
Lame dentée
Lama dentata



Anti-Wear Coating
(option for all mixing tools)
Verschleißschutz
(optional für alle Mischwerkzeuge)
Revêtement anti-usure reporté
(sur demande sur tous les outils)
Riporto antiusura
(a richiesta su tutti gli utensili)

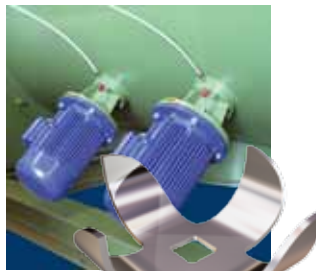

Tulip-Shaped Chopper - Kelch-Messerkopf
Chopper à calice - Chopper a calice

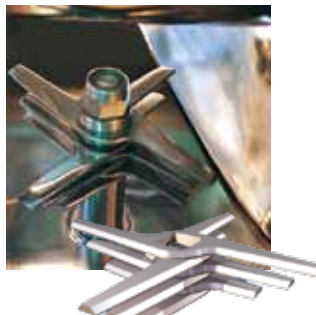

Blade-Type Chopper - Mehrfachmesserkopf - Chopper à lames - Chopper a lame



Liquid Injection Wands
Flüssigkeitszugabelnzen
Lances pour additivation liquides
Lancie per additivazione liquidi



Decompression Control
Dekompressionssteuerung
Tableau de décompression
Quadro di decompressione



Pneumatic Sampling Device
Pneumatischer Probenehmer
Prélévateur d'échantillons pneumatique
Preleva campioni pneumatico

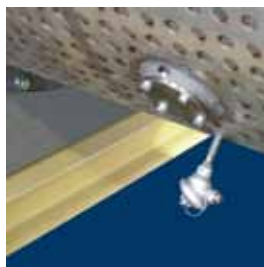

PT 100 Temperature Probe on Jacketed Mixing Chamber
PT 100 Temperatursonde auf Doppelmantel
Sonde thermométrique PT 100 sur double enveloppe
Sonda termometrica PT 100 su scambio termico

WBHT

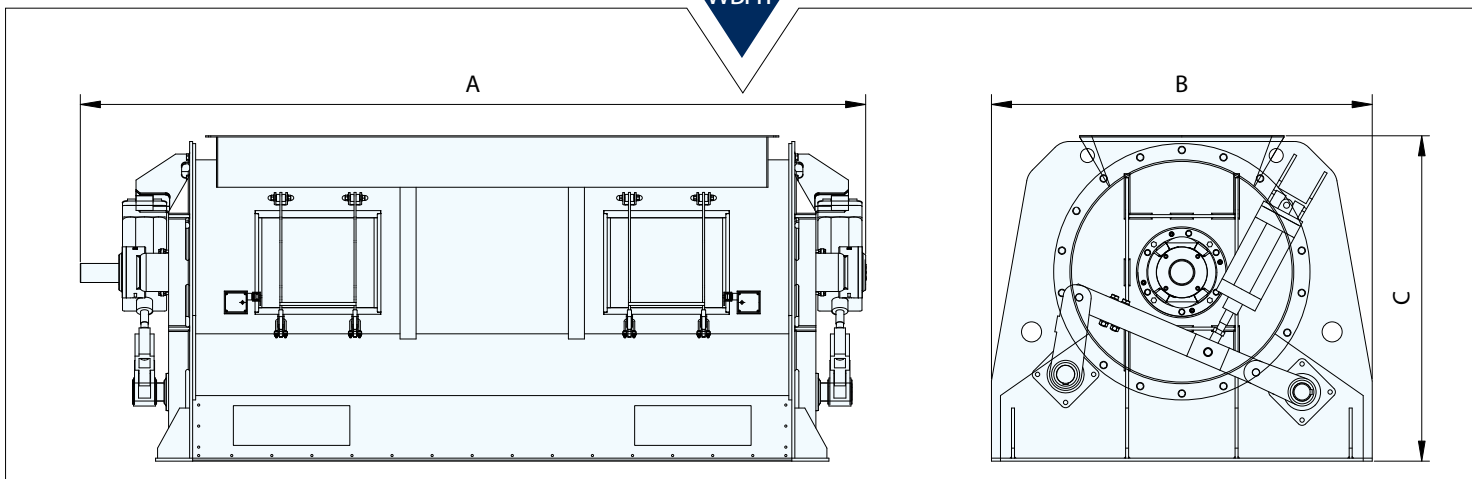

TYPE	A	B	C	Usable Volume Nutzinhalt Capacité Utile Capacità Mescolazione (dm ³)	Empty Weight Leergewicht Poids à Vide Peso a vuoto (kg)
WBHT 550 ☒	2150	1250	1200	385	690
WBHT 800 ☒	2350	1200	1250	560	850
WBHT 1100 ☒	2615	1500	1500	770	1200
WBHT 2000 ☒	2920	1900	1650	1400	2400
WBHT 3000 ☒	3920	1900	1650	2100	3000
WBHT 4800 •	4550	2000	1790	3360	3800
WBHT 6000 •	4870	1960	1900	4200	4400
WBHT 8800 •	5390	2200	2200	6160	5300
WBHT 10500 •	5630	2400	2430	7350	6900
WBHT 15000 •	6124	2800	2525	10500	8000

☒ Pneumatically operated bomb bay discharge door - Pneumatisch betriebene Entleerklappe - Portillon de vidange actionné pneumatiquement - Portello scarico ad azionamento pneumatico
 • Hydraulically operated bomb bay discharge door - Hydraulisch betriebene Entleerklappe - Portillon de vidange actionné hydrauliquement - Portello scarico ad azionamento idraulico

Indicative dimensions (mm)

WBHP

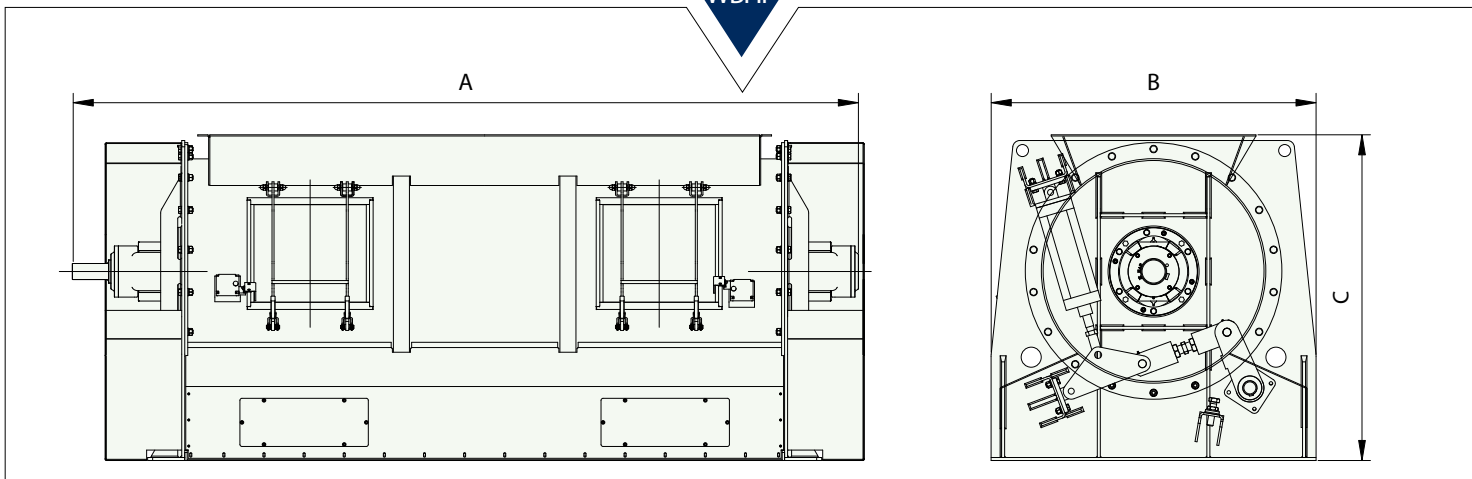

TYPE	A	B	C	Usable Volume Nutzinhalt Capacité Utile Capacità Mescolazione (dm ³)	Empty Weight Leergewicht Poids à Vide Peso a vuoto (kg)
WBHP 550	2150	1250	1200	385	650
WBHP 800	2400	1200	1250	560	810
WBHP 1100	2690	1350	1500	770	1100
WBHP 2000	3030	1500	1650	1400	2280
WBHP 3000	3900	1500	1650	2100	2550
WBHP 4800	4550	1780	1790	3360	3600
WBHP 6000	4820	1820	1970	4200	4200
WBHP 8800	5382	2000	2200	6160	5050
WBHP 10500	5630	2110	2400	7350	6500
WBHP 15000	6124	2380	2500	10500	7600

Pneumatically operated bomb bay discharge door - Pneumatisch betriebene Entleerklappe - Portillon de vidange actionné pneumatiquement - Portello scarico ad azionamento pneumatico

Indicative dimensions (mm)

Available from:

FILQUIP Pty Limited

5/126 Compton Rd, Underwood,
Qld 4119 Australia

Ph: +61 7 3208 3499 Fx: +61 7 3208 3449

Email: sales@filquip.com.au

www.filquip.com.au



www.wamgroup.com

Further Products - Weitere Produkte - Autre Production - Altra Produzione

