

Available from:
FILQUIP Pty Limited
5/126 Compton Rd, Underwood,
Qld 4119 Australia
Ph: +61 7 3208 3499 Fx: +61 7 3208 3449
Email: sales@filquip.com.au
www.filquip.com.au

Silo Venting Filter DUSTSHAKE™ R01

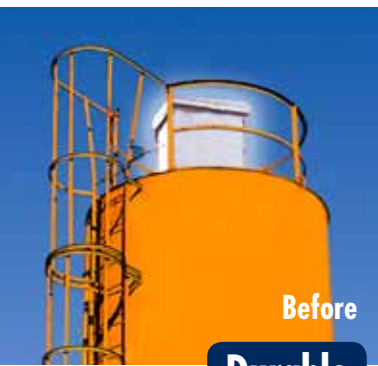

**Shaker
Cleaning System**



Durable



DUSTSHAKE™ R01 is a polygonal shaped **SILO VENTING FILTER** for silos which are filled by tankers.

Dust is separated from the dirty air flow by means of a multipocket polyester filter element. Dust drops back down into the silo after electromechanical shaking of the filter element.

- Stainless steel body
- Hinged top cover enables quick replacement of filter elements module
- Removable front panel for comfortable inspection of filter media
- Easy to install

Silo Filling



Dust is separated from the dirty air flow while clean air is evacuated from the filter

Filter Cleaning



Dust drops down into the silo due to shaking filter elements

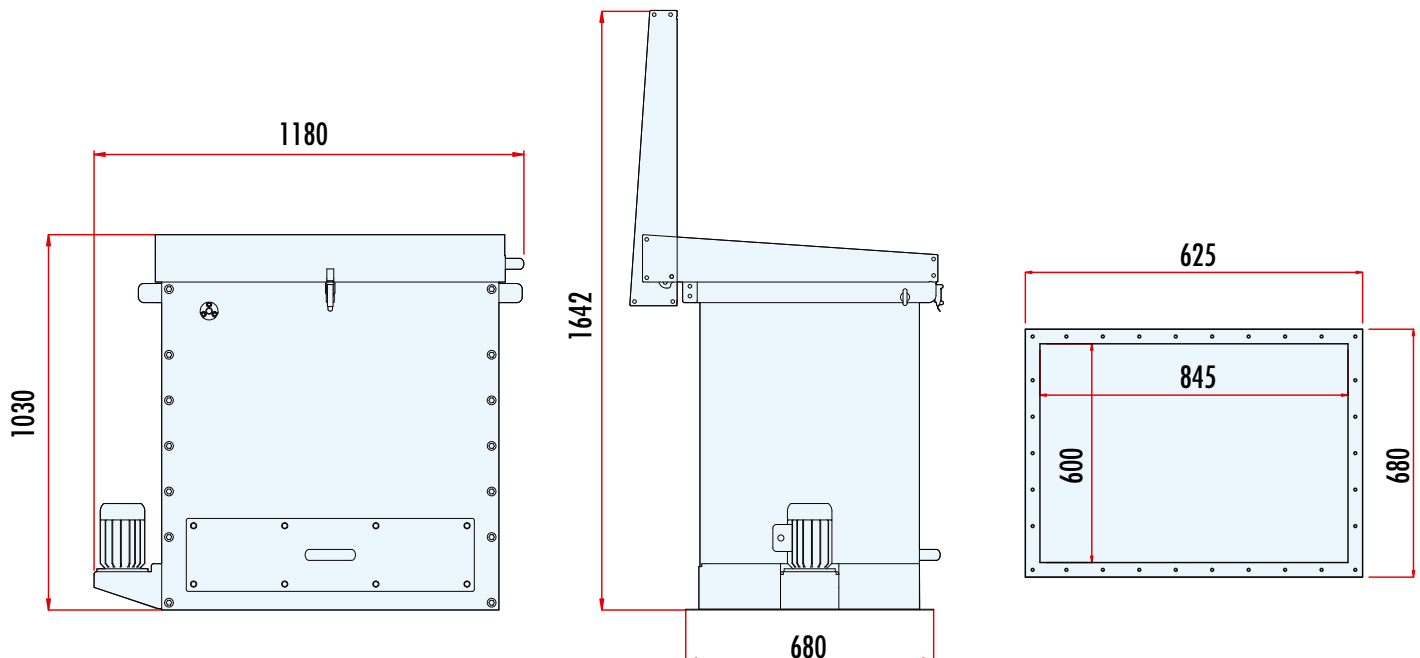

Available from:
FILQUIP Pty Limited

5/126 Compton Rd
Underwood Qld 4119
Australia

Phone: +61 7 3208 3499

Fax: +61 7 3208 3449

Email: sales@filquip.com.au

www.filquip.com.au



www.wamgroup.com