

Available from:
FILQUIP Pty Limited

5/126 Compton Rd, Underwood,
Qld 4119 Australia

Ph: +61 7 3208 3499 Fx: +61 7 3208 3449

Email: sales@filquip.com.au

www.filquip.com.au

Loading Bellows for IBCs and Drums

MINIFILL®

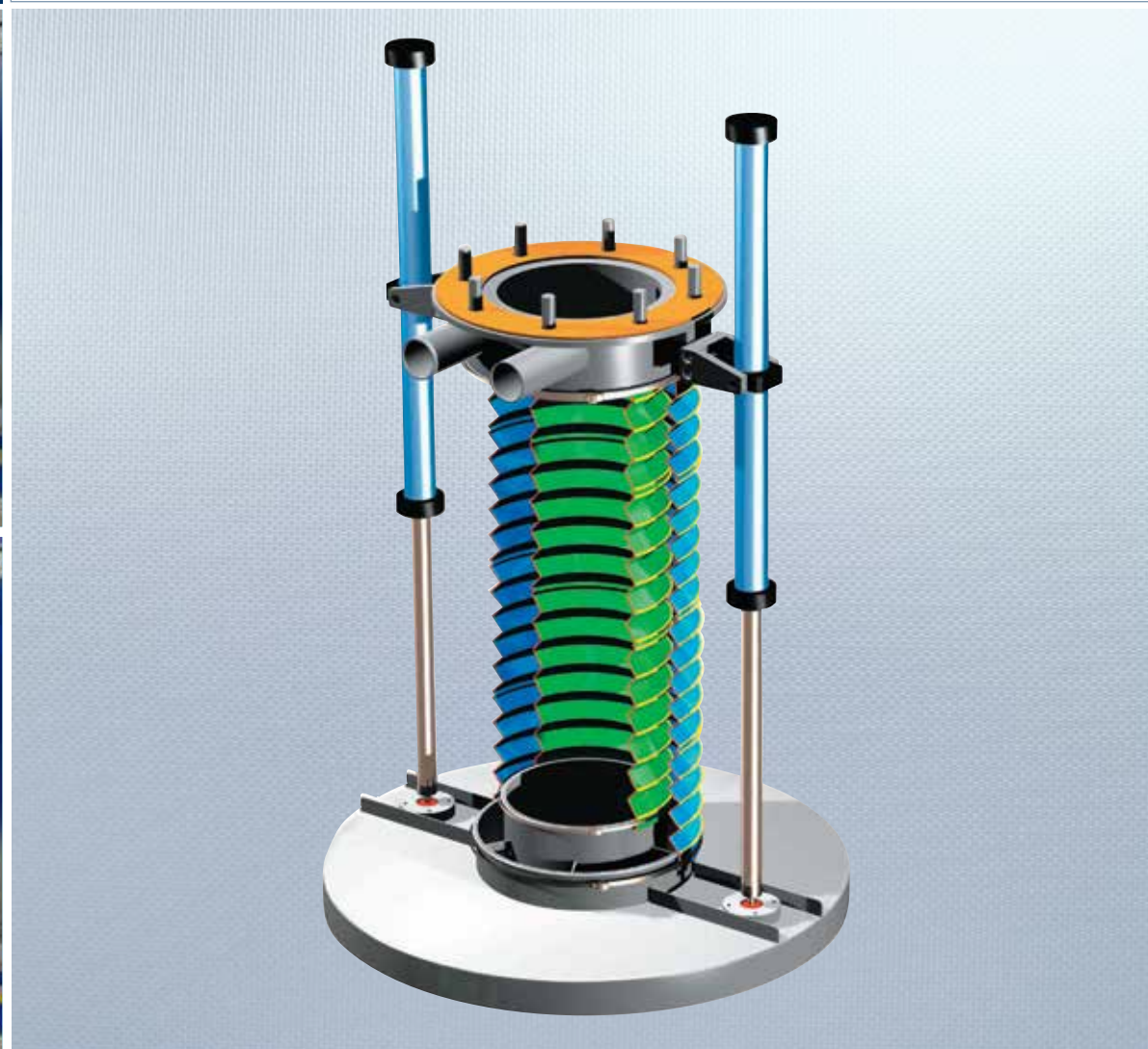

THE IDEAL SOLUTION FOR DUST-FREE LOADING OF BULK MATERIAL INTO DRUMS OR IBCs.

The compact overall dimensions of the MINIFILL® Loading Bellows for powdery materials is the perfect solution in limited space conditions.

Thanks to the double bellows design, the suction fan rate can be increased with very fine dust.

MINIFILL® Loading Bellows, powered by two pneumatic cylinders, is available in mild steel or stainless steel version.

Features

- Inlet Diameter: 200mm (8 in)
- Inlet Flange: UNI 2277 PN10 / DIN 2576 DN200 (XKFU10-D200 WAM® flanges)
- Maximum Capacity: 120 m³/h (70.6 cfm)
- Stroke: 500 mm (1.6 ft), 750 mm (2.4 ft), 1000 mm (3.2 ft)
- Working Temperature: from -15°C up to 120°C (5°F up to 248°F)
- Lifting Mechanism: two 48 kg pneumatic cylinders with 6 bar thrust
- N. 2 off external pneumatic cylinders not in contact with material flow extend and retract the loader
- Wear-resistant
- Solenoid Valve Supply: 24 V AC – 24 V DC – 110 V AC – 230 V AC
- Manufactured from mild steel or 304 stainless steel
- Double bellows, available in Hypalon®/Neoprene, food-grade polyester or Kevlar®

Overall Dimensions

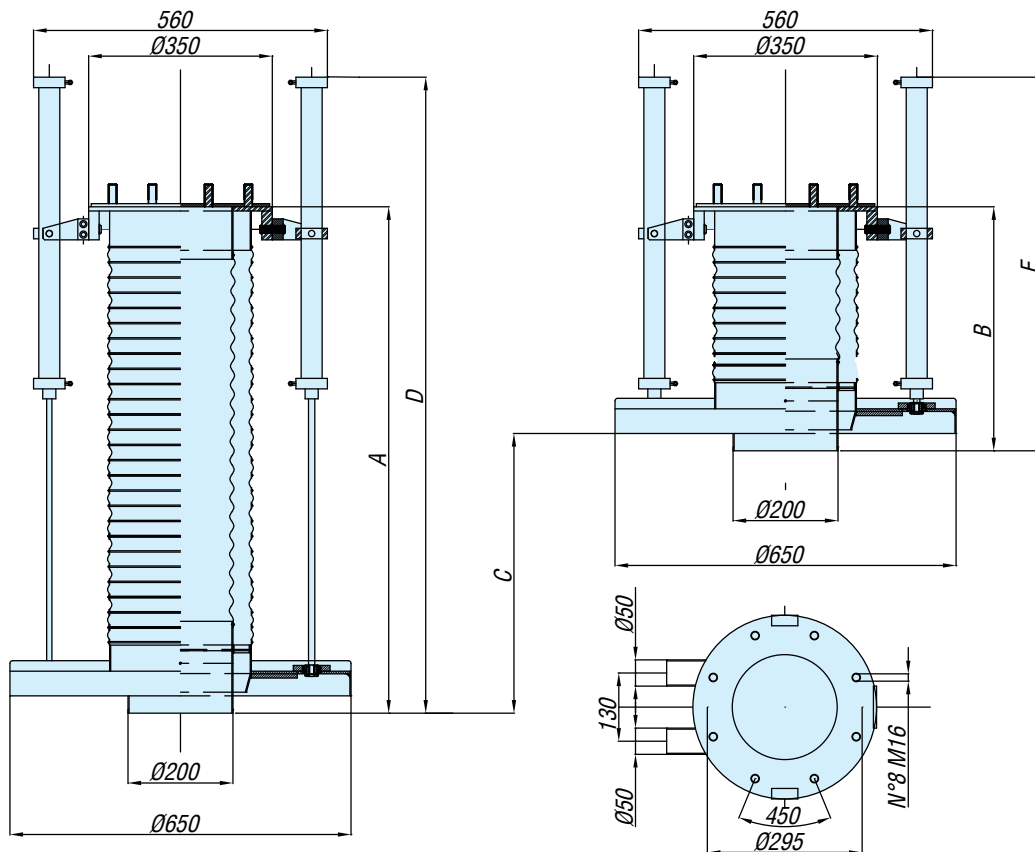

STROKE	A	B	C	D	E	WEIGHT
500 mm	965	465	500	1,212	712	35 kg
750 mm	1,465	715	750	1,712	962	37 kg
1000 mm	1,965	965	1,000	2,212	1,212	39 kg

Benefits

- ✓ Excellent dust-free material loading due to special design of the bottom plate;
- ✓ Available in various materials to fit each and every application;
- ✓ Reduced, space-saving overall dimensions.

1 Upper Head

Provided with stud bolts for flanged connection.
Pre-arranged with two pipes for the connection to a dust collector which filters the air contained between the two bellows.

3 Double Bellows

Material loaded through the MINIFILL® bellows into inlet spout of IBC or drum.

Made from different materials:



HYPALON®-NEOPRENE BELLOWS

- Flexible Neoprene bellows coated with Hypalon® stands for high resistance to atmospheric agents, abrasion and high temperature, making the loader particularly durable.



FOOD-GRADE POLYESTER

- Suitable for food products
- Antistatic



KEVLAR® BELLOWS

- Suitable for both high and low temperature applications

4 Bottom Plate

At the lower end of the Loading Bellows a wide bottom plate prevents spreading of dust in the environment during filling operation.

2 Pneumatic Cylinders

Used for lowering the bellows and connecting it to the drum or IBC to be filled.

Activated by solenoid valves.



Accessories

Reed Switch with Led



Voltage Supply: 12 ~ 24V AC - 9 ~ 24V DC

Used in all applications that require precise monitoring of the actuator position.
The signal can be interfaced for piloting of solenoid valves, relays or a PLC.
Protection against overvoltage during supply and switching.

Application



Available from:
FILQUIP Pty Limited

5/126 Compton Rd
Underwood Qld 4119
Australia
Phone: +61 7 3208 3499
Fax: +61 7 3208 3449
Email: sales@filquip.com.au
www.filquip.com.au



200001033 November 2013 Rights reserved to modify technical specifications.



www.wamgroup.com