

SOLIDS-LIQUID SEPARATION

Available from:  
**FILQUIP Pty Limited**

5/126 Compton Rd, Underwood,  
Qld 4119 Australia

Ph: +61 7 3208 3499 Fx: +61 7 3208 3449

Email: sales@filquip.com.au  
www.filquip.com.au

# SEPCOM®

## Animal Waste Separator

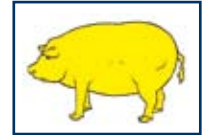
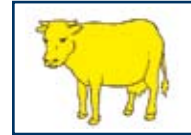

**MULTIPLE  
PATENTS PENDING**



# SEPCOM®

Animal waste separator  
SOLIDS-LIQUID SEPARATION

Specially formulated for this specific type of slurry, SEPCOM ® is simple, reliable, efficient and economical.

Re-using slurry offers enormous advantages in terms of transportation, storage, cleanliness and energy saving.

**Separating the solids in slurry from the liquid is THE ANSWER TO THE URGENT PROBLEM OF NITRATES.**

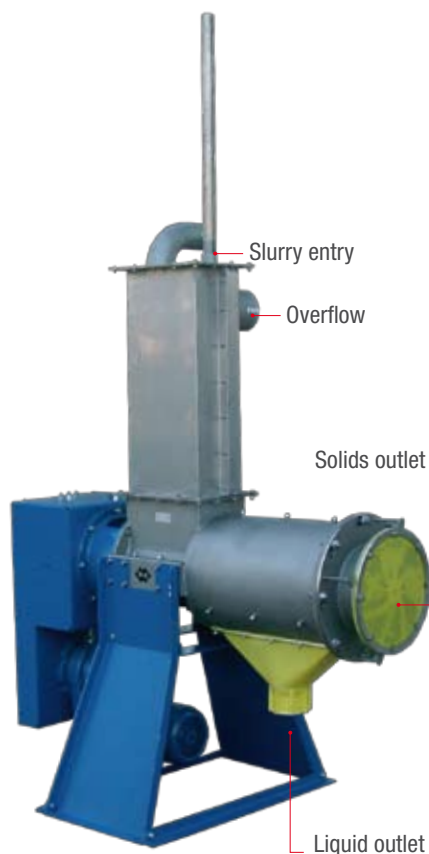

## LIQUID PHASE

- Easy to spread, mix, and pump
- Minimum residual sedimentation or incrustation
- Can be used for washing out sheds
- Excellent for ferti-irrigation



Flushing



Ferti-irrigation

## SOLID PHASE

- Shovelable, easy to store and convey
- Can be used as bedding for animals
- Excellent as soil ammdant
- The product can be marketed
- Odourless, non-percolating product



Shovelable, easy to transport and store even in enclosed spaces



Ideal cattle bedding



The product can be marketed

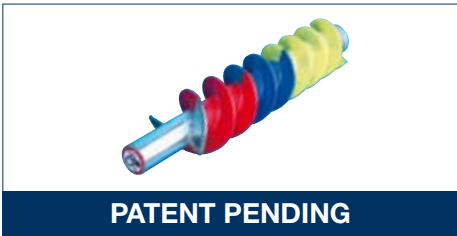

**PATENT PENDING**

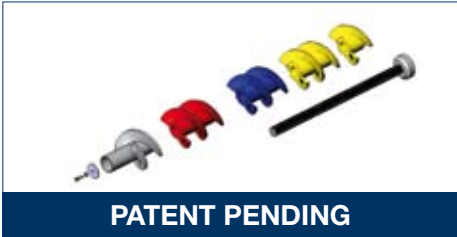

**PATENT PENDING**



**PATENTED**

Modular screw in technopolymer



Casing extension  
(This accessory increases capacity)

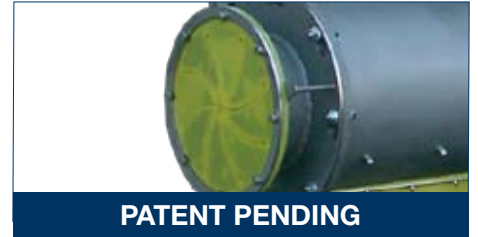

**PATENT PENDING**

Diaphragm outlet:  
self-adjusting back pressure

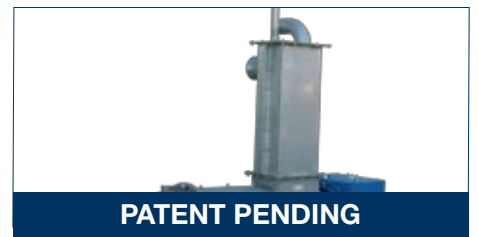

**PATENT PENDING**

Feeder: compensating buffer  
(obligatory accessory)

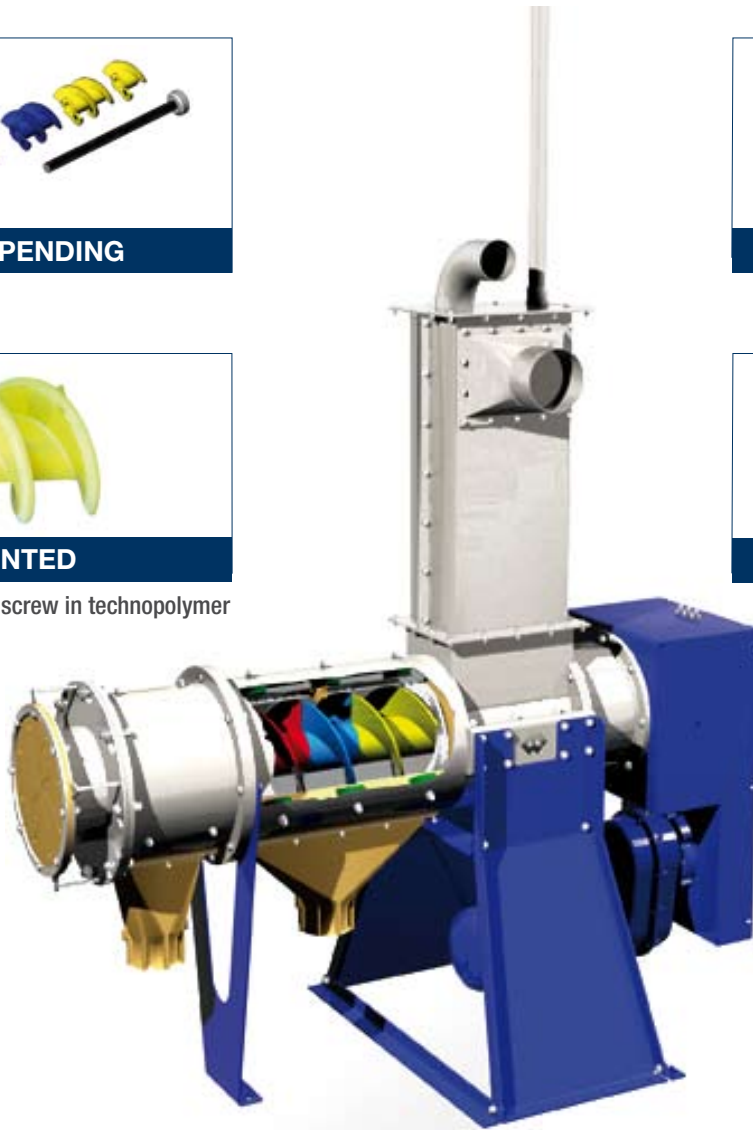

## COST COMPARISON BETWEEN AND OTHERS in 5 years\*:

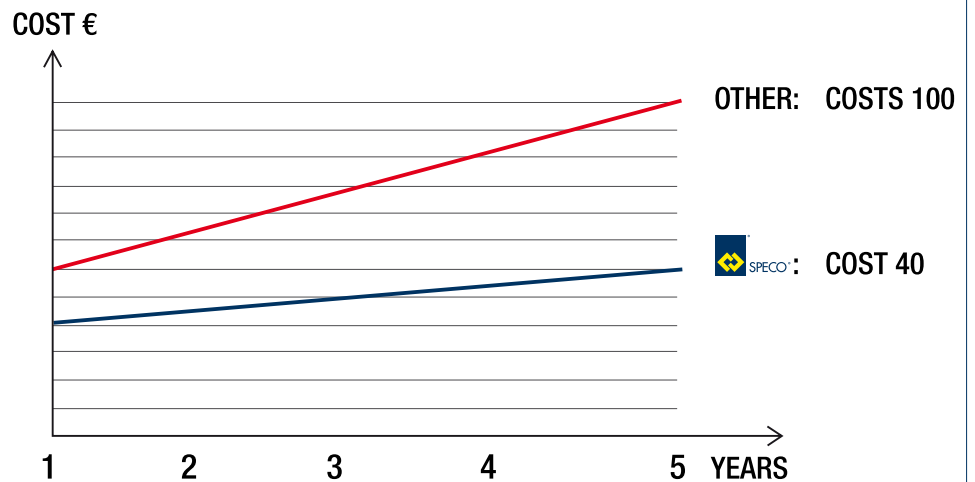

\* based on a usage of 4 hectares/day

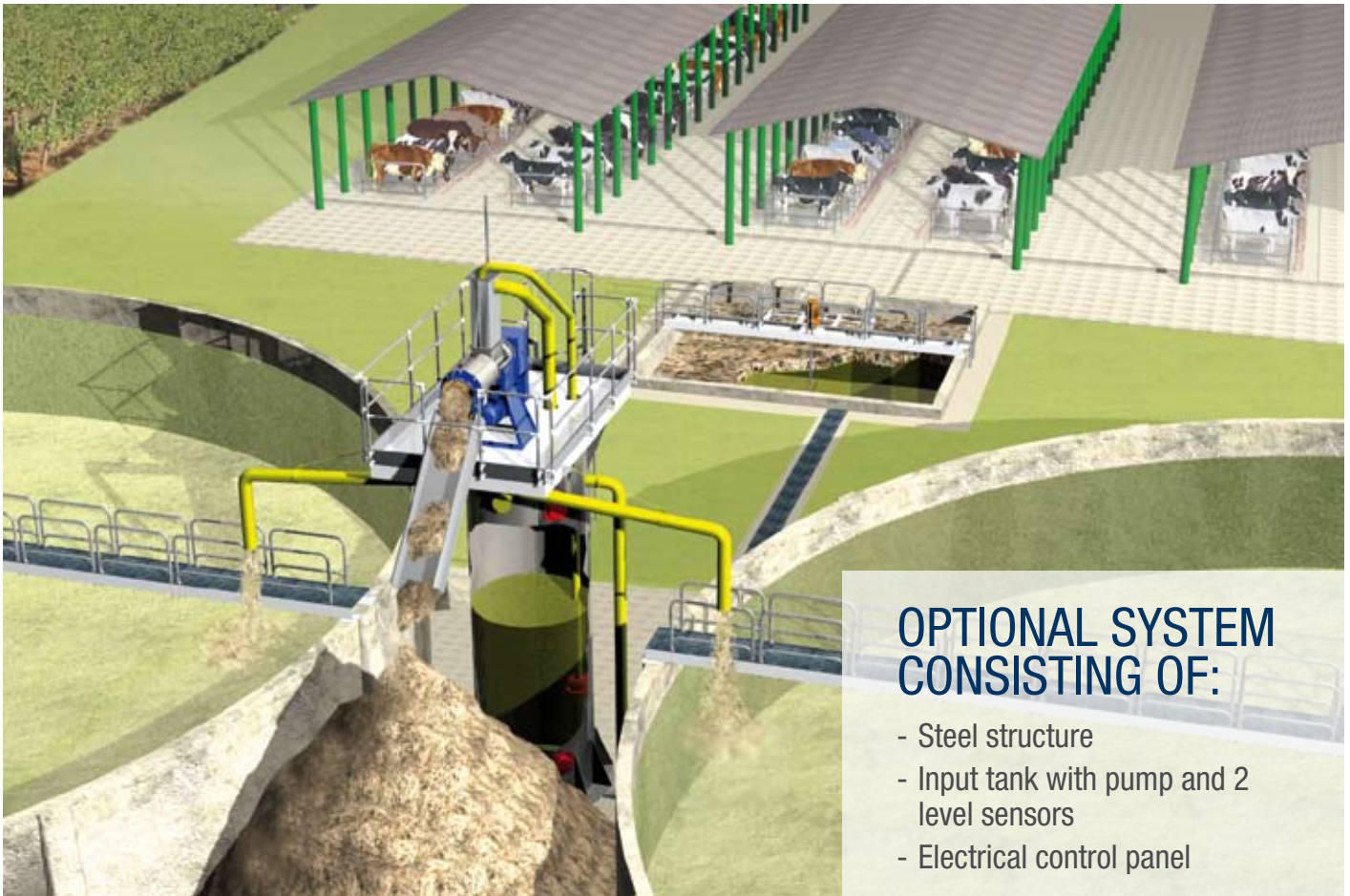

## OPTIONAL SYSTEM CONSISTING OF:

- Steel structure
- Input tank with pump and 2 level sensors
- Electrical control panel

### STANDARD VERSION

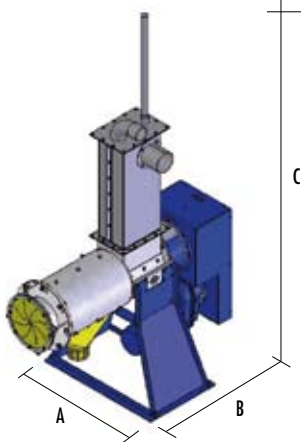

### EXTENDED VERSION

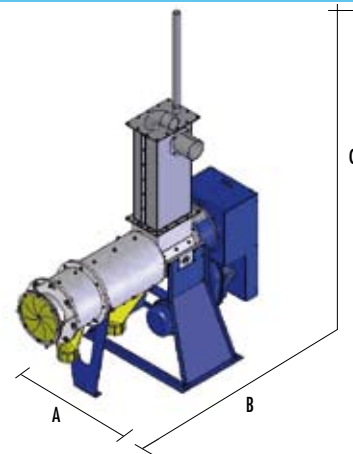

RANGE	A mm	B mm	C mm	Power consumption kW	Weight kg	Max. capacity m <sup>3</sup> /h*
SEPCOM® 045	975	1.622	2.767	4	490	45
SEPCOM® 065	975	1.922	2.767	5.5	580	65

Body in carbon steel or stainless steel.  
Screw in self-cleaning technopolymer.  
Sieve in stainless steel.

\* Capacity may vary depending on the type of input material, working conditions, and maintenance of the machine.



SPECO® - Division of WAM S.p.A.  
Via Cavour, 338  
I - 41030 Ponte Motta  
Cavezzo (MO) - ITALY

Tel: +39 0535 61 81 11  
Fax: +39 0535 61 82 26  
info@wamgroup.com  
www.wamgroup.com

Available from:  
**FILQUIP Pty Limited**

5/126 Compton Rd, Underwood,  
Qld 4119 Australia  
Ph: +61 7 3208 3499 Fx: +61 7 3208 3449  
Email: sales@filquip.com.au  
www.filquip.com.au