



PO BOX 3043 Logan DC
Qld 4114 Australia
5/126 Compton Rd
Underwood Qld 4119

Phone: +61 7 3208 3499
Fax: +61 7 3208 3449
Email: sales@filquip.com.au

Filquip Centralised Industrial Vacuum Systems

Centralised industrial vacuum systems have become integral components in the safe cleaning and operation of mills for flour, sugar, animal feed and many other plants that handle organic powders and granules which are combustible dusts.

Our Filquip Centralised Industrial Vacuum Systems utilise quality German and Italian manufactured equipment combined collection hoppers and frames fabricated at our workshop in Queensland, Australia.

The NFPA guidelines (National Fire Protection Association) as referenced by Australian Standards recommends hazardous area rated centralised industrial vacuum systems for explosion risk mitigation by safe cleaning of combustible dusts in factories.

Key features include; Anti-static filters, earthed piping and collector unit, stainless steel equipment components, IECEX rated motors and electrical instrumentation/equipment for within the hazardous zone.

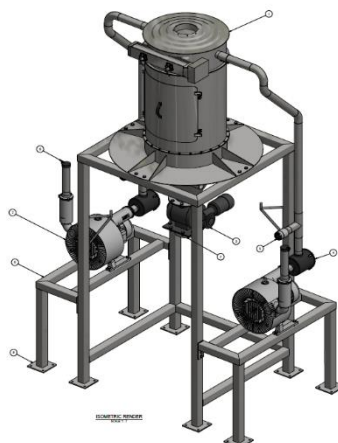
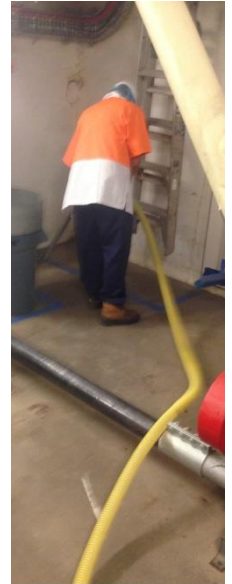

"Specialists in material handling equipment for powders & granules."