

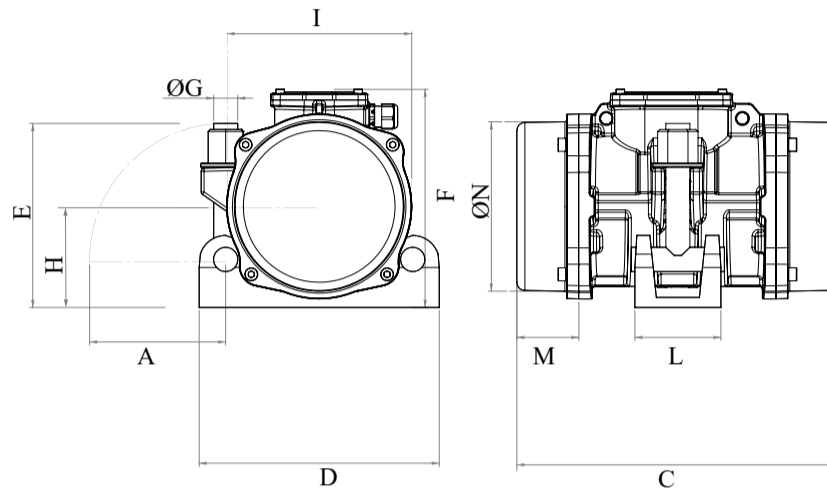

# MVE 1530/6N-HC-38A0 [CN40153038A0BA0000]

3 PH - 4 poles - 6000 RPM - 220-240/400-460 V - 200 Hz

Working moment [Kg*cm]	Unbalance [Kg*cm]	Centrifugal force [Kg]	Nominal voltage [V]	Input power [kW]	Current [A]	Power factor	Ia/In
6,82	3,41	1.373	220-240/400-460	1	Δ 2,8 Y 1,62	0,89	



OVERALL DIMENSIONS [mm]												
Weight [Kg]	G	Holes number	A	E	C	L	M	N	I	F	H	D
10,9	22	1	68	172	276	190	43	156	174	200	94,5	190

TECHNICAL FEATURES						
Type of grease	Greased for life	Screw	Washer	Clamping torque [Nm]	Cable type	Cable gland
/	Yes	M20	21 x 37 mm	185	4G2.5 80°C	M25 120°C

BEARINGS				
Bearing model	Type	Life 100%	Life 80%	Life 50%
6306 2Z		/	/	/

CERTIFICATION	
Atex II 3D Ex tc IIIc Tx IP66 [Tx Size 10-30:100°C - Tx Size 40-91:135°C] T.Amb -20/+40°C	   